



## OptiView™ On-line UV Transmittance Monitor

The OptiView™ measures the UV transmittance (UVT) of drinking water continuously, accurately and in real-time. When paired with a TrojanUV system, the OptiView helps ensure that your water is being treated with the proper dose of UV and gives you confidence that you are maintaining regulatory compliance.

### Key Benefits

**Highly Accurate for Upper UVT Ranges:** The OptiView is designed specifically for drinking water applications where UVT is between 70 and 100%. The way it measures UVT is unique in the industry and ensures a highly accurate and reliable reading that compensates for lamp and/or sensor sleeve fouling.

**Save Energy Costs:** By having real-time UVT data, you can avoid overdosing by matching water quality with its required UV dose. When UVT is high, banks of lamps can be turned off or lamp output can be adjusted to extend lamp life and conserve power by up to 25%.

**Easy Data Integration:** Data from the OptiView can be input directly into a control loop for most UV systems, a SCADA system, or both.

**Maintenance in Minutes:** Maintenance can be completed in minutes and without tools. It consists of an annual lamp replacement and sensor calibration as well as a quick clean of the sensor and lamp sleeve every 3 months.

**Reduce Grab Sampling and Maintain Regulatory Compliance:** Everyday grab sampling is no longer required, significantly reducing daily workload. OptiView samples water both on a set frequency and automatically if it suspects a change in UVT, ensuring accurate and reliable monitoring.

**Compact Design:** The OptiView's small size and wall-mountable design makes it easy to integrate into existing treatment facilities.

### What Is UV Transmittance?

UVT is the ratio of light entering the water to that exiting the water. Simply put, water with high UVT allows more UV light to reach the organisms you are trying to treat. As water quality decreases, the UVT is reduced, which in turn reduces the amount of UV light that is able to penetrate and provide treatment.

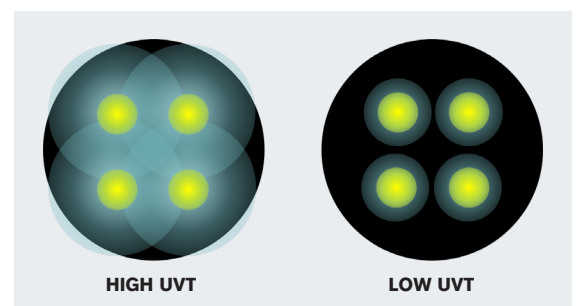

## How it Works

When a water sample enters the inlet, the motor moves the sensor window so two measurements at different water layers can be taken and compared to determine UVT. This method of measurement ensures an accurate and reliable UVT reading that compensates for lamp and/or sensor sleeve fouling.

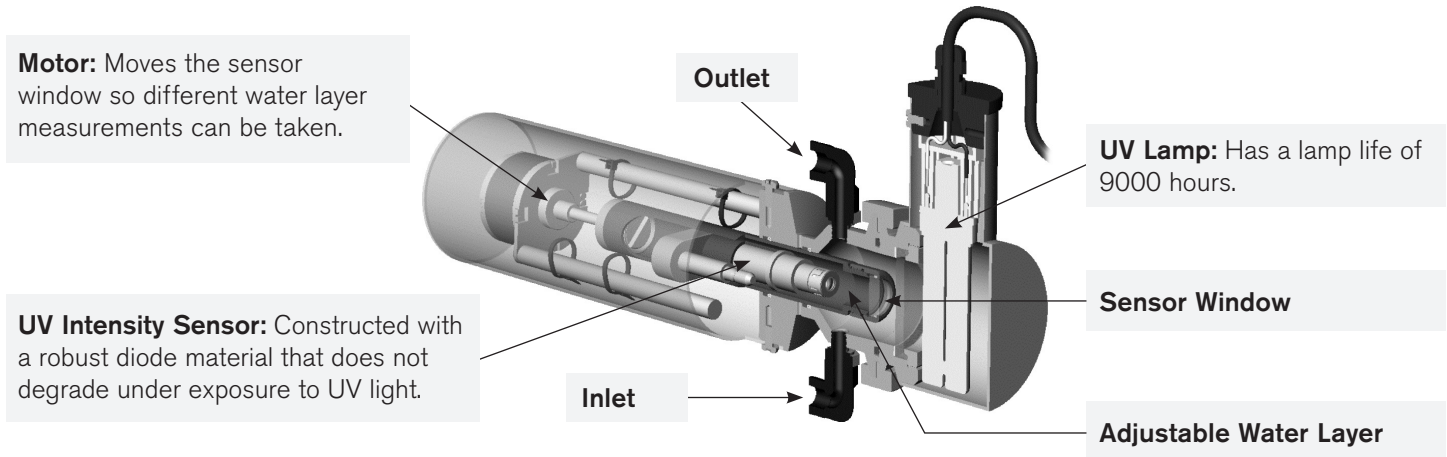

## Specifications

Dimensions	20" x 20" x 10" (51 cm x 51 cm x 25 cm)
Weight	65 lbs (30 kg)
Power	"Plug & Play" automatically adjusts to 100 – 240V at 50 – 60Hz
Enclosure	304 Stainless Steel, NEMA Type 4X (IP65) rated
Installation	Wall-mountable
UVT Range	70-100% at 254 nm adjusted to a 1 cm path length
Acceptable Turbidity Range	0-5 NTU
Lamp Life	9000 hours
Accuracy	+/- 1.5% FSD
Measurement Frequency	Can be set for every 1 – 20 minutes
Communication - outputs	2 x continuous 4-20 mA corresponding to 70–100 % transmittance of process stream, single discrete common alarm

## Save Capital Equipment Costs

If you are thinking about installing a UV treatment system, putting an OptiView in place beforehand can help save up to 20% in capital equipment costs. By having a comprehensive set of UVT data available for your water, we can determine exactly how much UV equipment and lamps are needed to most cost-effectively implement UV at your facility.

To learn more about the brands and affiliates of Trojan Technologies, please visit [www.trojantechnologies.com](http://www.trojantechnologies.com)